

Air cooled cooling only:
40-400HP (112-1030kW)

Air to Water heat pump:
40-240HP (106-585kW)

Water cooled cooling only:
40-240HP (134-696kW)

Water cooled cooling only
condenserless:
40-120HP (120-360kW)



samurai range

Screw Type Water Chillers
Cooling Only & Heat Pump Versions

HITACHI
Inspire the Next



Contents

Company profile	4
Product range	5
Features & benefits	6
Technical specification	10
Technical description	18
Options & accessories	20
Quality process & maintenance	24

Air Conditioning from HITACHI can justifiably be described as the art of exploiting the latest ideas and developments in technology to create a range of innovative products which provide more comfortable and more productive environments in which people can happily live and work. It is also an art executed with a responsible concern for protecting the environment. Ecological thinking begins at the very first stages of new product design and continues throughout production, installation procedures, equipment and operation.

Specifiers and users alike can always be assured that performance and costs are not the only parameters by which HITACHI products can be judged.

To achieve success with such objectives on a global scale requires not only enormous resources but also a commitment to the future. As one of the largest companies in the world, with over 347,424 employees, HITACHI is well positioned to undertake this commitment with the confidence that comes from successfully responding to the changing needs of people for over 90 years.

In 1992 HITACHI invested in a new purpose built, state of the art factory (HAPE) in Barcelona, Spain. The site of the factory was carefully chosen to accommodate further building on its 40,000 square metre site. The creation of a European manufacturing facility and customer training centre helps to reduce production costs, speed up delivery times and enables full support to be given to all customers.

HITACHI's advanced air conditioning products are specified all over the world, wherever there is a requirement for ultimate performance and cost effective, long term reliability. A wide range of units coupled with a choice of advanced control systems mean HITACHI can provide solutions to meet every possible air conditioning application or specification. Authorised Distributors all over the world contribute their own specialised technical support and practical assistance to provide individual system designs, commissioning and after sales service. HITACHI Authorised Distributors are committed to providing unrivalled support from a combination of experienced engineers, local product and spare parts stock,

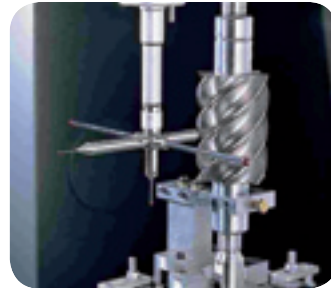

Medium 3D instrument for the screw compressor rotors.



HITACHI Air Conditioning Products Europe HAPE Works, Spain.

Company profile

HITACHI - in Japanese the name means sunrise - is at the forefront of research and development turning new ideas and innovations into new products. Of its \$80.9 billion sales worldwide, close to 4.3% was invested in research and development programs. This vast amount of money has given HITACHI the opportunity to conceive many "world firsts" - examples of which include the technologically advanced and acclaimed scroll and semi-hermetic Screw compressors. These have been incorporated in HITACHI's air conditioning systems and water chillers which have revolutionised air conditioning worldwide.

supported in turn by on-going technical support from HITACHI.

From the initial product concept at HITACHI's research and development facility in Japan, product development is dedicated to providing the products the customer requires. Product design and development is continuous with priority being given to the use of new, ecologically friendly refrigerants. To satisfy your cooling and heating requirements and to ensure the optimum indoor environment, consider HITACHI the first and last word in air conditioning.



Hitachi Appliances Inc., Shimizu Works, Japan.



Product range

The Hitachi Samurai Range is available in a capacity range of 106kW to 1030kW and is manufactured and tested in our state of the art production facility: HAPE, located just outside Barcelona in Spain. The Samurai air-cooled chiller is available in both Cooling Only and Heat Pump versions, Cooling Only from 112kW to 1030kW and Heat Pump from 106kW to 585kW. The Samurai water-cooled chiller is available from 120kW to 696kW (optional heating mode from 161kW - 824kW) and is one of the most efficient water-cooled chillers available today.

A key factor enabling such a compact footprint is the use of plate heat exchangers for both the condenser and evaporator. Both air and water-cooled ranges utilise Hitachi's own highly reliable and efficient twin screw compressor. When combined with Hitachi's advanced electronic control system the Samurai chiller is able to provide full modulation capacity control, therefore allowing the chiller to accurately match the required cooling load whilst maintaining the outlet water temperature to within +/- 0.5 degrees.



Models	40	50	60	70	80	100	120	140	160	180	210	240	280	320	350	400
RCUE Air Cooled Cooling Only (AG2)*	●															
Capacity (kW)	112	130	156	178	206	260	312	356	412	468	534	618	712	824	890	1030



Models	40	50	60	70	80	100	120	140	160	180	210	240	270	300	330	400
RHUE Air Cooled Heat Pump (AG2)*	●															
Capacity (kW)	106	123	148	169	195	246	296	338	390	444	507	585				
	110	127	152	185	185	254	305	371	371	457	556	556				



Models	40	50	60	80	100	120	150	180	200	240	270	300	330	400	
RCUE Water Cooled Cooling Only (WG2)	●														
Capacity (kW)	134	160	194	232	320	388	445	525	600	696					
(with optional heating function)	161	192	233	274	384	467	526	621	719	824					



Models	40	50	60	80	100	120	140	150	160	180	200	210	240	270	300	330	400	
RCUE Water Cooled Cooling Only Condenser Less (CLG)	●																	
Capacity (kW)	120	145	180	240	290	360												

*copper fin available on request, NOT STANDARD

Precise Control of Outlet Water Temperature

Continuous capacity control is based on precise control of the water outlet temperature, depending on the thermal requirements of the load. This is reflected in lower operation costs as the unit will only provide the energy needed for the load.

To control the water temperature the SAMURAI uses two essential components as follows:

1. A sliding valve in the screw compressor to change the refrigerant circuit variables, adapting them to the requested load.
2. A sophisticated electronic system based on control bands in which the aim is to maintain a constant outlet temperature.

There are 4 bands which can be configured:

- LOAD UP 1 BAND
- LOAD UP 2 BAND
- NEUTRAL BAND
- LOAD DOWN BAND

Given a load and having selected a water outlet temperature, the electronic system compares the value measured by thermistors with the desired value. Depending on the measured value, and at one-minute intervals, a control signal is generated that varies the position of the sliding valve either to increase or to decrease the capacity as required.

The control signal is sent to the solenoid valves located in the compressor and those valves command the sliding valve's movements. The signal has a variable length therefore the slider repositioning will be variable according to the control band.

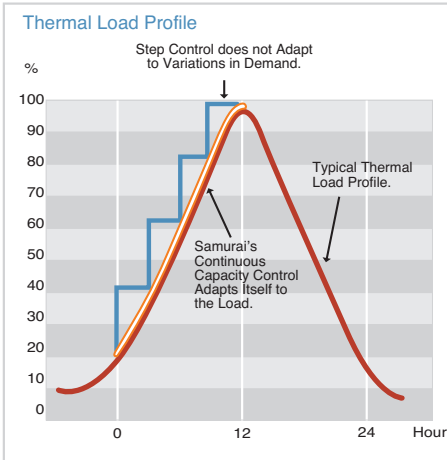

The combination of the two can be summarized in the diagram to the left.

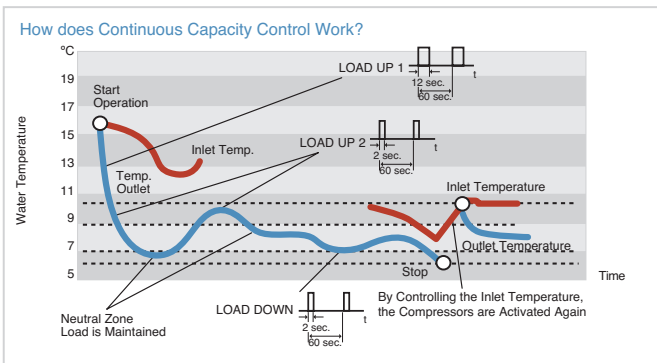

Features & benefits



When the band LOAD UP 1 is selected, the signal will last for 12 seconds. When the band LOAD UP 2 or LOAD DOWN is selected, the signal will last 2 seconds. When the NEUTRAL BAND is selected, the slider will stay where it is, as will the capacity.

The great advantage of this system is that it has control bands with different behaviours so the unit is better able to adapt to load requirements. When a quick response is needed (when the measured temperature is very different from the desired temperature), the system can be programmed to provide quick control.

When a precise response is required (when the measured temperature is close to the desired temperature), it can be programmed to give a more precise response.

Compared to PID control systems, the advantage is that a faster response time can be achieved. The response in LOAD UP 1 is significantly quicker than a PID system, hence so is achieving the desired results.

Also the system's great flexibility permits the installer to adapt the response times or the system's precision to that specific installation. This is done by means of a simple programming of the microswitches in the micro-processor (see the Technical Catalogue).

Low Noise & Super Low Noise

Sound levels and vibration are key factors during the operation of a chiller. In many applications it may be necessary to limit the sound level to permitted values, depending on local regulations.

The SAMURAI chillers operate at low sound and vibration levels due to the technical development of the HITACHI semi-hermetic screw compressors, precise machining and meticulous assembly during the production process. The compressors are mounted on rubber pads that protect the structure of the chiller from possible compressor vibrations, which is why the overall result is absolutely balanced.

Low Sound

Hitachi uses high technology to achieve the lowest sound. The new two bladed propellers, rather than four bladed, achieves a reduction of noise level, increases air flow volume, and at the same time provides an important reduction of motor power input.

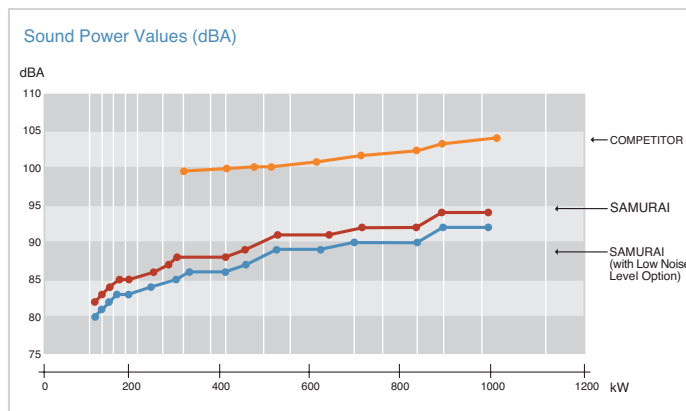
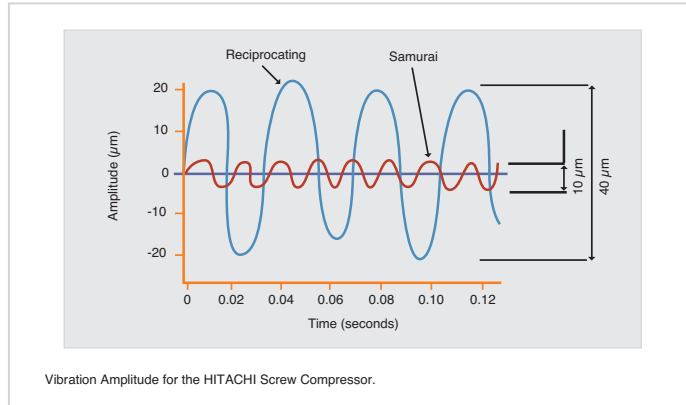

The compressors are installed in an enclosure and covered with acoustic insulating material to further reduce the sound level as far as possible. The fans are also specifically designed to reduce noise while permitting sufficient circulation of air for the correct operation of the unit. The new AG2 unit is fitted with a DC Inverter Fan in order to adapt the air flow more efficiently and therefore control the discharge pressure and the acoustic impact. It is also possible to select the unit with the "Low Noise and Super Low Noise" options. In this case, the insulation of the compressor enclosure increases. Therefore it is possible to achieve a further reduction of 4 dBA. These features of the SAMURAI chiller can help to reduce the overall installation costs as it can eliminate the need for any acoustic screens or external sound attenuation packages.

Air Cooled Models Efficiency at Partial Load

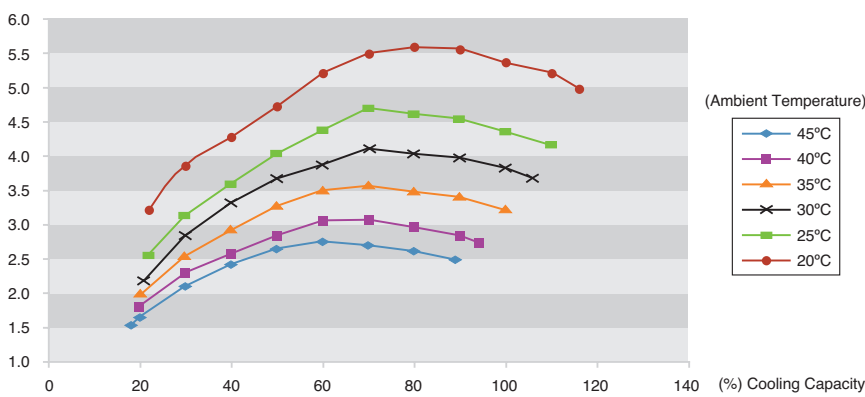

OPERATIONAL COST SAVING (+)

Annual Power Consumption (KW/h/year)

Reciprocating Type

100%

Step Capacity Control

87%

Continuous Capacity Control

66%

SAMURAI

(+) Based on Typical thermal load for air conditioning. HITACHI's comparison.

Excellent Partial Load Performance

As the Samurai utilizes continuous capacity control it is able to match the required cooling capacity accurately. This enables the Samurai to control on outlet water temperature rather than inlet. Additionally, thanks to the meticulous design of the control system, the performance of the unit at partial loads is excellent. As can be seen, the variations in the input capacity are smaller than the variation of the unit's cooling capacity. This leads to an increased COP at partial loads and a significant advantage over competitor's chillers.

ESEER (In accordance with Eurovent)

The ESEER (European seasonal energy efficiency ratios) are published in the opposite table for the AG2 chiller. This indicates the average energy efficiency at part load based upon the four operating conditions defined by Eurovent.

Model	40AG2	50AG2	60AG2	70AG2	80AG2	100AG2	120AG2	140AG2	160AG2	180AG2	210AG2	240AG2	280AG2	320AG2	350AG2	400AG2
ESEER	3.21	3.58	3.51	3.5	3.48	3.58	3.49	3.49	3.48	3.5	3.51	3.48	3.5	3.48	3.5	3.48

New Electronic Expansion Valve

These units are equipped with an electronic expansion valve to provide sophisticated control under any temperature conditions.

The electronic expansion valve provides reduced electrical power consumption compared to the classical system.



Minimum Amount of Refrigerant

SAMURAI chillers use a stainless steel plate heat exchanger as the evaporator. This exchanger is far more compact than the traditional shell & tube type heat exchangers. It takes up far less space even though it exchanges the same capacity.

Thanks to this technological development, SAMURAI requires the lowest charge of refrigerant on the market. This leads to lower operating costs once the system is in operation, as the amount of refrigerant that may need to be replaced during maintenance operations will be minimal.

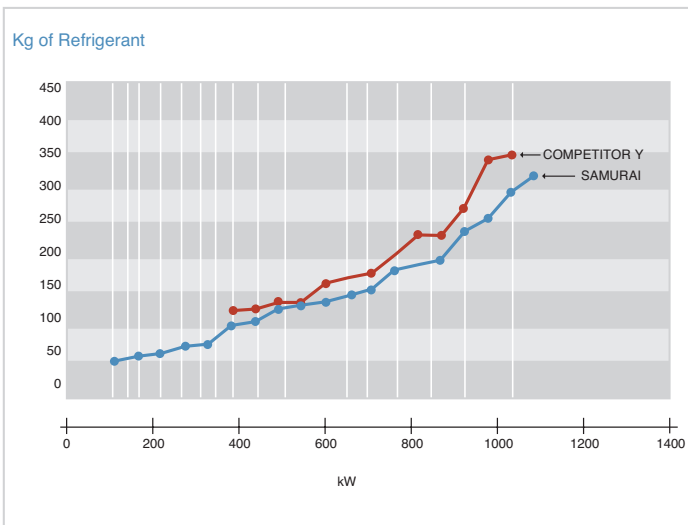

Features & benefits



Small Installation Space

Often the space available for the installation of a chiller is a critical factor. Obstacles plus the lack of space are usually a decisive factor when selecting the equipment to be installed in HVAC facilities. Due to the meticulous design of each and every component, it is possible to achieve exceptionally high cooling capacity values per square meter installed with HITACHI Samurai chillers. Due to the design quality it is easy to access all of the major components and subsequently the service access required for the chiller can be reduced to a minimum.

Figure shows cooling capacity values per square meter installed, using the model HITACHI RCUE 80 AG2 and similar models from competitors.

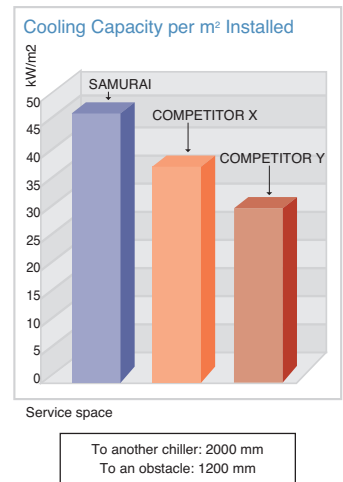

Ideal Starting System

The electrical starting system in the SAMURAI range prevents you from having to install oversized electrical wiring due to the peak currents that are usually caused by conventional chillers. This is due mainly to two reasons.

Firstly, the compressor's electrical motors have a STAR-DELTA starting system which is installed as standard equipment in each compressor and allows a significant reduction in the compressor's starting power.

Secondly, SAMURAI chillers employ a staged start-up process. If the system has more than one compressor, start-up begins with the unit that has worked the least hours. This compressor is run at minimum load so as to minimize the power load on the installation. After a one-minute delay the second compressor is then started. Both compressors continue to run at minimum load as the next compressor begins to operate, and so on, until all the compressors are working at minimum load. After a thirty second safety delay the machine increases to normal (rated) power.

Staged start-up in this way has two basic advantages. Firstly, the instantaneous power consumption by each compressor during start-up is lower than if all the compressors were started simultaneously. Secondly, given that start-up power is minimized, cable dimensions are not affected and at no time is the system subjected to overloading.

Minimum Amount of Water in the Installation

To prevent an excessive number of compressor starts and stops, which results in reducing their useful life, the installation must have a minimum amount of water to provide the system with the required thermal inertia.

This minimum required volume depends on how good the control system is and what is the minimum capacity of the unit.

SAMURAI chillers require a small installed volume since the capacity control range is very wide (15%-100%). Furthermore, by utilising the optional function (volt free contact) this external contact can be installed in the Electrical Box in order to control the compressor/s of the unit. This minimum possible capacity makes it possible to reduce the minimum installation volume when required, in accordance with the following figures:

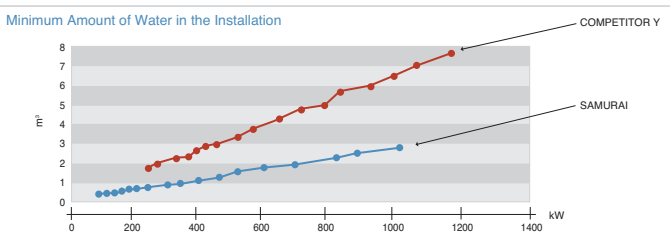

Reduction in Instantaneous Electrical Power Consumption

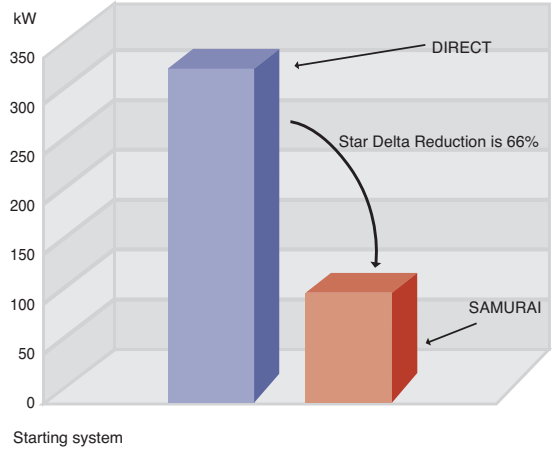

Reduction in Instantaneous Electrical Power Consumption

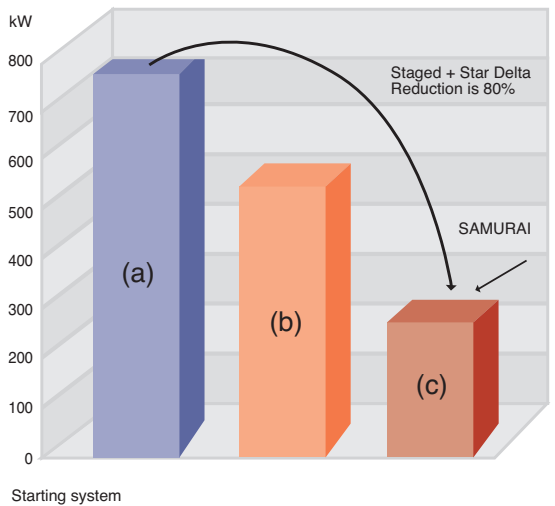

- (a) Direct starting of 3 compressors simultaneously.
- (b) Star-delta starting of 3 compressors simultaneously.
- (c) Combined star-delta + staged HITACHI starting.

High Power Factor

Electricity companies usually charge extra for consuming the reactive energy used in electric motors to generate the magnetic field that is necessary for them to work. SAMURAI chillers operating in nominal conditions have a high power factor - normally exceeding a value of 0.9 at full load. It is therefore not necessary to install a series of capacitors to compensate for the reactive energy consumed, since this is minimal.



RCUE Air Cooled Cooling Only



General Data

Models (RCUE)		40AG2	50AG2	60AG2	70AG2	80AG2	100AG2	120AG2	140AG2	160AG2	180AG2	210AG2	240AG2	280AG2	320AG2	350AG2	400AG2	
Cooling Capacity	kW	112	130	156	178	206	260	312	356	412	468	534	618	712	824	890	1030	
Total Power Input	kW	36.4	42.7	52.3	59.8	69.6	85.4	104.5	119.6	139.1	156.8	179.4	208.7	239.2	278.2	299	347.8	
COP	–	3.1	3.0	3.0	3.0	3.0	3.0	3.0	3.0	3.0	3.0	3.0	3.0	3.0	3.0	3.0	3.0	
Outer Dimension																		
Height	mm	2,430	2,430	2,430	2,430	2,430	2,430	2,430	2,430	2,430	2,430	2,430	2,430	2,430	2,430	2,430	2,430	
Width	mm	1,900	1,900	1,900	1,900	1,900	1,900	1,900	1,900	1,900	1,900	1,900	1,900	1,900	1,900	1,900	1,900	
Depth	mm	2,150	2,150	2,150	2,750	2,750	4,050	4,050	5,250	5,250	5,950	7,750	7,750	10,250	10,250	12,750	12,750	
Cabinet Colour		Natural Grey									Natural Grey							
Shipping Weight	kg	1,430	1,470	1,560	1,760	1,820	2,830	3,000	3,420	3,550	4,450	5,070	5,250	6,750	7,000	8,450	8,750	
Compressor Type	–	Semi-Hermetic Screw Type									Semi-Hermetic Screw Type							
Models	–	40ASC-Z	40ASC-Z	50ASC-Z	60ASC-Z	60ASC-Z	40ASC-Z	50ASC-Z	60ASC-Z	60ASC-Z	50ASC-Z	60ASC-Z	60ASC-Z	60ASC-Z	60ASC-Z	60ASC-Z	60ASC-Z	
Quantity	–	1	1	1	1	1	2	2	2	2	3	3	3	4	4	5	5	
Oil Heater	W	150					150x2			150x2	150x3			150x4		150x5		
Capacity Control		Continuous Capacity Control									Continuous Capacity Control							
Working Range	%	15 ~100									15 ~100							
Water Cooler Type	–	Brazing Plate Type									Brazing Plate Type							
Condenser Type	–	Multi-Pass Cross Finned Tube									Multi-Pass Cross Finned Tube							
Fan Motor (pole)	kW	0.38(8)									0.38(8)							
Quantity	–	4	4	4	6	6	8	8	12	12	12	18	18	24	24	30	30	
Refrigerant		R407C									R407C							
Type	–	R407C									R407C							
Charge	kg	39	46	49	59	64	46 x 2	49 x 2	59 x 2	64 x 2	49 x 3	59 x 3	64 x 3	59 x 4	64 x 4	59 x 5	64 x 5	
Flow Control		Electrical Expansion Valve									Electrical Expansion Valve							
Number of Circuit	–	1	1	1	1	1	2	2	2	2	3	3	3	4	4	5	5	
Oil Type	–	Japan Energy Freol UX300 (Ester)									Japan Energy Freol UX300 (Ester)							
Evaporator		Stainless steel plate heat exchanger brazed with copper									Stainless steel plate heat exchanger brazed with copper							
Type		Stainless steel plate heat exchanger brazed with copper									Stainless steel plate heat exchanger brazed with copper							
Nominal Water Flow	m³/h	19.3	22.4	26.8	30.6	35.4	44.7	53.7	61.2	70.9	80.5	91.8	106.3	122.5	141.7	153.1	177.2	
Pressure Drop	kPa	21.9	24.7	23.6	30.3	40.1	24.6	23.6	30.3	40.1	23.4	30.1	39.8	30.5	40.3	30.1	39.9	
Max. Pressure	MPa	1.0									1.0							
Connections	inches	3" Victaulic (1xInlet / 1xOutlet)					3" Victaulic (2xInlet / 2xOutlet)			3" Victaulic (2xInlet / 2xOutlet)	3" Victaulic (3xInlet / 3xOutlet)			3" Victaulic (4xInlet / 4xOutlet)		3" Victaulic (5xInlet / 5xOutlet)		
Control System	–	Micro-Processor Control									Micro-Processor Control							
Chilled Water outlet		5 ~ 15 (-10 °C Option)									5 ~ 15 (-10 °C Option)							
Temperature	°C	5 ~ 15 (-10 °C Option)									5 ~ 15 (-10 °C Option)							
Condenser Air Inlet		-15 ~ 46									-15 ~ 46							
Temperature	°C	-15 ~ 46									-15 ~ 46							
Sound Power Level	dB	82	83	84	85	85	86	87	88	88	89	91	91	92	92	94	94	
Sound Pressure Level	dB (A)	64	65	66	67	67	67	68	69	69	69	70	70	71	71	72	72	
Power Supply	–	3~, N / 380V-415V / 50Hz									3~, N / 380V-415V / 50Hz							

Notes

Cooling capacity, input power, flow rate and water pressure drop calculated according to EN12055 for standard conditions.
(Ambient = 35°C, chilled outlet water = 7°C and chilled inlet water = 12°C, Condenser water inlet 30°C and condenser water outlet 35°C, Refrigerant saturated vapour temperature =45°C)

Heating capacity according to EN12055 for standard conditions (Ambient = 8°C DB, outlet water = 45°C, inlet water = 40°C)

(1) Low temperature applications are as an option (see chapter for options)

(2) High condensing temperature applications are available as an option (see chapter for options).

(3) Sound power values according to EUROVENT test. Sound pressure measured to 1.5m height and 1m from control panel.



RHUE Air to Water Heat Pump



General Data

Models (RHUE)		40AG2	50AG2	60AG2	70AG2	80AG2	100AG2	120AG2	140AG2	160AG2	180AG2	210AG2	240AG2
Cooling Capacity	kW	106	123	148	169	195	246	296	338	390	444	507	585
Total Power Input in Cooling	kW	36.4	42.7	52.3	59.8	69.6	85.4	104.5	119.6	139.1	156.8	179.4	208.7
COP (cooling)	–	2.9	2.9	2.8	2.8	2.8	2.9	2.8	2.8	2.8	2.8	2.8	2.8
Heating Capacity	kW	110	127	152	185	185	254	305	371	371	457	556	556
Total Power Input in Heating	kW	40.7	44.5	54.3	67.7	67.7	89	108.6	135.5	135.5	162.9	203.2	203.2
COP (heating)	–	2.7	2.9	2.8	2.7	2.7	2.9	2.8	2.7	2.7	2.8	2.7	2.7
Outer Dimension													
Height	mm	2,430	2,430	2,430	2,430	2,430	2,430	2,430	2,430	2,430	2,430	2,430	2,430
Width	mm	1,900	1,900	1,900	1,900	1,900	1,900	1,900	1,900	1,900	1,900	1,900	1,900
Depth	mm	1,900	1,900	1,900	2,500	2,500	3,800	3,800	5,000	5,000	5,700	7,500	7,500
Cabinet Colour	–	Natural Grey						Natural Grey					
Shipping Weight	kg	1,550	1,600	1,670	1,880	1,950	3,050	3,250	3,670	3,780	4,780	5,440	5,650
Compressor Type	–	Semi-Hermetic Screw Type						Semi-Hermetic Screw Type					
Models	–	40ASC-Z	40ASC-Z	50ASC-Z	60ASC-Z	60ASC-Z	40ASC-Z	50ASC-Z	60ASC-Z	60ASC-Z	50ASC-Z	60ASC-Z	60ASC-Z
Quantity	–	1	1	1	1	1	2	2	2	2	3	3	3
Oil Heater	W	150					150x2	150x2			150x3		
Capacity Control	–	Continuous Capacity Control						Continuous Capacity Control					
Working Range	%	15 ~100						15 ~100					
Water Side Heat Exchanger	–	Brazing Plate Type						Brazing Plate Type					
Air Side Heat Exchanger	–	Multi-Pass Cross Finned Tube						Multi-Pass Cross Finned Tube					
Fan Motor (pole)	kW	0.38(8)						0.38(8)					
Quantity	–	4	4	4	6	6	8	8	12	12	12	18	18
Refrigerant													
Type	–	R407C						R407C					
Charge	kg	39	46	49	64	64	46 x 2	49 x 2	64 x 2	64 x 2	49 x 3	64 x 3	64 x 3
Flow Control	–	Electronic Expansion Valve						Electronic Expansion Valve					
Number of Circuit	–	1	1	1	1	1	2	2	2	2	3	3	3
Oil Type	–	Japan Energy Freol UX300 (Ester)						Japan Energy Freol UX300 (Ester)					
Evaporator													
Type	–	Stainless steel plate heat exchanger brazed with copper						Stainless steel plate heat exchanger brazed with copper					
Nominal Water Flow	m ³ /h	18.2	21.2	25.5	29.1	33.5	42.3	50.9	58.1	67.1	76.4	87.2	100.6
Pressure Drop	kPa	19.7	22.2	21.3	23.5	30.9	22.2	21.3	23.4	30.8	21.1	23.6	31.1
Max. Pressure	MPa	1.0						1.0					
Connections	inches	3" Victaulic (1xInlet / 1xOutlet)					3" Victaulic (2xInlet / 2xOutlet)	3" Victaulic (2xInlet / 2xOutlet)			3" Victaulic (3xInlet / 3xOutlet)		
Control System													
Control System	–	Micro-Processor Control						Micro-Processor Control					
Chilled Water Outlet Temp	°C	5 ~ 15 (-10°C Option)						5 ~ 15 (-10°C Option)					
Heated Water Outlet Temp	°C	35 ~ 55						35 ~ 55					
Condenser Air Inlet Temp	°C	-15 ~ 46 for Cooling Operation						-15 ~ 46 for Cooling Operation					
Evaporator Air Inlet Temp	°C	DB:-9.5 ~ 21/ WB:-10 ~ 15.5 for Heating Operation						DB:-9.5 ~ 21/ WB:-10 ~ 15.5 for Heating Operation					
Permissible Water Pressure Max.	MPa	1.0						1.0					
Sound Power Level	dB	82	83	84	85	85	86	87	88	88	89	91	91
Sound Pressure Level	dB (A)	64	65	66	67	67	67	68	69	69	69	70	70
Power Supply	–	3~, N / 380V-415V / 50Hz						3~, N / 380V-415V / 50Hz					

Notes

Cooling capacity, input power, flow rate and water pressure drop calculated according to EN12055 for standard conditions. (Ambient = 35°C, chilled outlet water = 7°C and chilled inlet water = 12°C, Condenser water inlet 30°C and condenser water outlet 35°C, Refrigerant saturated vapour temperature =45°C). Heating capacity according to EN12055 for standard conditions (Ambient = 8°C DB, outlet water = 45°C, inlet water = 40°C

- (1) Low temperature applications are as an option (see chapter for options)
- (2) High condensing temperature applications are available as an option (see chapter for options).
- (3) Sound power values according to EUROVENT test. Sound pressure measured to 1.5m height and 1m from control panel.



RCUE Water Cooled Cooling Only



General Data

Models (RCUE)		40WG2	50WG2	60WG2	80WG2	100WG2	120WG2	150WG2	180WG2	200WG2	240WG2
Cooling Capacity	kW	134	160	194	232	320	388	445	525	600	696
Total Power Input	kW	33.5	40	49.1	54.5	80	98.2	104.5	123.5	148.5	163.5
GOP	–	4.0	4.0	4.0	4.3	4.0	4.0	4.3	4.3	4.0	4.3
Outer Dimension											
Height	mm	1,542	1,542	1,542	1,542	1,700	1,700	1,700	1,660	1,660	1,660
Width	mm	1,045	1,045	1,045	1,045	1,104	1,104	1,104	1,105	1,105	1,105
Depth	mm	844	844	844	844	1,430	1,430	1,430	2,420	2,420	2,420
Cabinet Colour	–	Natural Gray									
Shipping Weight	kg	750	765	830	950	1570	1670	1770	2500	2580	2670
Compressor Type	–	Semi-Hermetic Screw Type									
Models	–	40ASC-Z	50ASC-Z	60ASC-Z	60ASC-Z	50ASC-Z	60ASC-Z	60ASC-Z	50ASC-Z	60ASC-Z	60ASC-Z
Quantity	–	1	1	1	1	2	2	2	3	3	3
Oil Heater	W	150				150 x 2			150 x 3		
Oil Type	–	Japan Energy Freol UX300 (Ester)									
Capacity Control		Continuous Capacity Control									
Working Range	%	For 1 compressor: 15~100				For 2 compressors: 15(7.5)~100			For 3 compressors: 15(5)~100		
Refrigerant		R407C									
Type	–	R407C									
Flow Control	–	Electronic Expansion Valve									
Number of Circuits	–	1				2			3		
Control System	–	Micro-Processor									
Condenser		Stainless steel plate heat exchanger brazed with copper									
Type	–	Stainless steel plate heat exchanger brazed with copper									
Nominal Flow	m³/h	28.8	34.4	41.8	49.3	68.8	83.6	94.5	111.5	128.7	147.8
Pressure Drop	kPa	37.1	37.3	39.1	61.8	67.8	72.2	91.1	31.3	41	61.8
Max. Pressure	MPa	1.03									
Connections	inches	3" Victaulic (1xInlet / 1xOutlet)				3" Victaulic (1xInlet / 1xOutlet)			3" Victaulic (3xInlet / 3xOutlet)		
Evaporator		Stainless steel plate heat exchanger brazed with copper									
Type	–	Stainless steel plate heat exchanger brazed with copper									
Nominal Water Flow	m³/h	23	27.5	33.4	39.9	55	66.7	76.5	90.3	103.2	119.7
Pressure Drop	kPa	30.8	36.7	35.8	43.1	37.7	54.3	70.5	29.4	37.9	43.1
Max. Pressure	MPa	1.03									
Connections	inches	3" Victaulic (1xInlet / 1xOutlet)				3" Victaulic (1xInlet / 1xOutlet)			3" Victaulic (3xInlet / 3xOutlet)		
Chilled Water Outlet Temp	°C	5 ~ 15									
Cooling Water Outlet Temp	°C	22 ~ 45									
Sound Power Level	dB	83	84	86	86	88	90	90	91	92	93
Sound Pressure Level	dB (A)	68	69	71	71	72	74	74	75	76	77
Power Supply	–	3~, N/380-415V/50Hz									
Safety and Protection Devices		Reverse Phase Protection Device, Fuse and Thermal Relay for Compressor, Internal Thermostat for Compressor, Compressor Oil Heater, Control Circuit Fuse, High Pressure Switch, Low Pressure Control, Suction Gas Temperature Control, Freeze Protection Control and Compressor Operation Hour Meter									

Notes

Cooling capacity, input power, flow rate and water pressure drop calculated according to EN12055 for standard conditions. (Ambient = 35°C, chilled outlet water = 7°C and chilled inlet water = 12°C, Condenser water inlet 30°C and condenser water outlet 35°C, Refrigerant saturated vapour temperature =45°C). Heating capacity according to EN12055 for standard conditions (Ambient = 8°C DB, outlet water = 45°C, inlet water = 40°C

- (1) Low temperature applications are as an option (see chapter for options)
- (2) High condensing temperature applications are available as an option (see chapter for options).
- (3) Sound power values according to EUROVENT test. Sound pressure measured to 1.5m height and 1m from control panel.



RCUE Water Cooled Cooling Only Condenserless



General Data

Models (RCUE)		40CLG	50CLG	60CLG	80CLG	100CLG	120CLG
Cooling Capacity	kW	120	145	180	240	290	360
Total Power Input	kW	34.4	42.4	52.1	68.8	84.8	104.2
GOP	–	3.5	3.4	3.5	3.5	3.4	3.5
Outer Dimension							
Height	mm	1,343	1,343	1,343	1,531	1,531	1,531
Width	mm	1,064	1,088	1,152	1,184	1,184	1,184
Depth	mm	935	935	935	1,432	1,432	1,432
Cabinet Color	–	Natural Gray			Natural Gray		
Shipping Weight	kg	630	680	730	1200	1310	1380
Compressor Type	–	Semi-Hermetic Screw Type			Semi-Hermetic Screw Type		
Models	–	40ASC-Z	50ASC-Z	60ASC-Z	40ASC-Z	50ASC-Z	60ASC-Z
Quantity	–	1	1	1	2	2	2
Oil Heater	W	150			150 x 2		
Oil Type	–	Japan Energy Freol UX300 (Ester)			Japan Energy Freol UX300 (Ester)		
Capacity Control		Continuous Capacity Control			Continuous Capacity Control		
	%	15 ~ 100			15 ~ 100		
Refrigerant Type	–	R407C			R407C		
Flow Control	–	Thermal Expansion Valve			Thermal Expansion Valve		
Number of Circuits	–	1			2		
Evaporator	–	Brazing Plate Type			Brazing Plate Type		
Control System	–	Micro-Processor			Micro-Processor		
Piping Connections							
Evaporator							
Type	–	Stainless steel plate heat exchanger brazed with copper					
Nominal Flow	m ³ /h	20.6	24.9	31	41.3	49.9	61.9
Pressure Drop	kPa	26.5	24.5	24.4	43.9	50.6	64.7
Max. Pressure	MPa	1.03			1.03		
Connections	inch	3" Victaulic (1 x INLET / 1 x OUTLET)			4" Victaulic (1 x INLET / 1 x OUTLET)		
Refrigerant Gas Piping	mm	Ø41.3 (Outer Diameter)			Ø41.3 (Outer Diameter) x 2		
Refrigerant Liquid Piping	mm	Ø28.6 (Outer Diameter)			Ø28.6 (Outer Diameter) x 2		
Chilled Water Outlet Temp	°C	5 ~ 15			5 ~ 15		
Condensing Temp	°C	30 ~ 55			30 ~ 55		
Sound Power Level	dB (A)	82	84	86	86	87	89
Sound Pressure Level	dB (A)	68	69	71	71	72	74
Power Supply	–	3 ~ ,N / 380-415V / 50Hz			3 ~ ,N / 380-415V / 50Hz		
Safety and Protection Devices		Reverse Phase Protection Device, Fuse and Thermal Relay for Compressor, Internal Thermostat for Compressor, Compressor Oil Heater, Control Circuit Fuse, High Pressure Switch, Low Pressure Control, Suction Gas Temperature Control, Freeze Protection Control and Compressor Operation Hour Meter			Reverse Phase Protection Device, Fuse and Thermal Relay for Compressor, Internal Thermostat for Compressor, Compressor Oil Heater, Control Circuit Fuse, High Pressure Switch, Low Pressure Control, Suction Gas Temperature Control, Freeze Protection Control and Compressor Operation Hour Meter		

The SAMURAI water chillers are compact, air-cooled and equipped with continuous capacity microprocessor controlled screw compressors.

They are delivered pre-charged with HFC R-407C (chlorine-free) refrigerant. Cooling only and Heat Pump versions are available. All units undergo a complete commercial test, checking that all the components are operating correctly. It is therefore only necessary to make the electric and hydraulic connections at the installation site.

The new ichi-ban semi hermetic screw compressor

The Semi-hermetic screw compressor has been designed to work with the refrigerants R22 and R407C. As it is directly connected to the electric motor it is not necessary to provide external electric motor connections which reduces the number of internal components.

The compressors are mounted on anti-vibration rubber pads and are situated inside a sealed enclosure. This enclosure is patented by HITACHI, and reduces noise because it has a double coating.

Due to the pressure difference between the high-pressure chamber and the low-pressure enclosure, lubricating oil is continuously supplied to the mechanical parts and to the moving piston that provides continuous capacity control. This system removes the need for an oil pump, adjustment valves, and associated mechanisms.

The new cyclonic oil separator is located inside the casing of the compressor so there is no need for any external oil pipes which results in a compact design and high compressor reliability.

Each compressor includes:

- Bipolar electric motor with star-delta starting circuit (standard)
- Solenoid valves for continuous capacity control
- Electronic protection against high temperature, with centralized manual reset
- New cyclonic oil separator, oil level and sight glass
- Mechanical operating time counter.

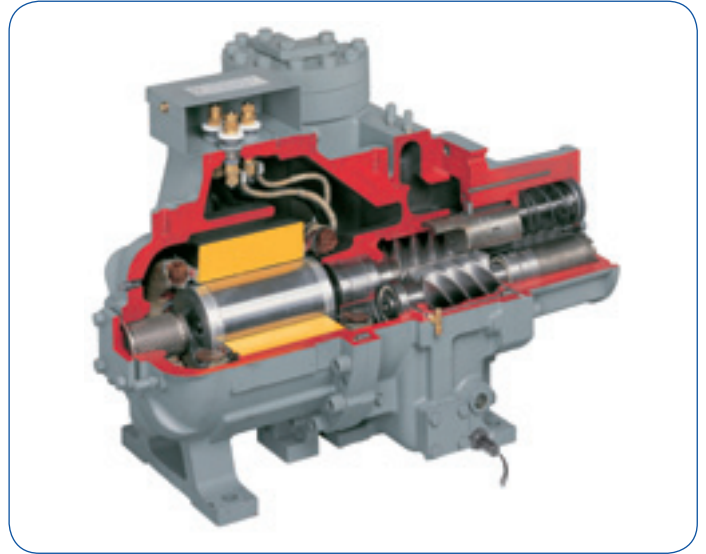

Technical description

BMS Interface (HARC70-CE1)

In case of connection to a Building Management System (available as an option), it is possible to manage:

- Unit On/Off
- Adjust the cold/heat water set point (outlet temperature)
- Adjust cooling/heating mode

You can monitor:

- ON/OFF
- Selected cold water temperature
- Actual cold/heat water temperature
- Alarm codes
- Operation status

For this function it is necessary to select the HARC70-CE1 interface from the options list. This interface permits the connection of up to 4 chillers using HLINK connection (HITACHI communications protocol).

The communications protocol is LONWORKS.



Water Side Heat Exchanger

The SAMURAI chiller range uses an innovative plate heat exchanger. This exchanger allows the inner volume in the refrigerant cycle to be reduced, thus obtaining the maximum efficiency with the least possible amount of refrigerant. It is fabricated from AISI-316 stainless steel plate to prevent any corrosion.

Both refrigerant and water pass either side of profiled plates in contra-flow, across which the heat exchange occurs. These plates are profiled to induce turbulence in both the water and refrigerant flow in order to increase the efficiency and optimize the heat exchange process both in time and in space.

With R407C, the cooling capacity of this type of exchanger is greater than traditional shell and tube type evaporators.

Air Side Heat Exchanger

The air side heat exchangers are constructed from copper tubes and aluminium fins (copper fins are an option), to the HITACHI patented "Slit Fin" design. The high efficiency of the aluminum fins combined with the internally grooved copper tubing make it possible to achieve a high heat transfer rate and a very compact size.

The fins are covered with a protective layer of anticorrosion as standard.

DC Fan Motor with Outstanding Efficiency

The DC fan motor greatly improves efficiency compared to conventional products using an AC motor. Also, air blasts are reduced by controlling the rotation speed of the fan.

PWM (pulse width modulation) concept of speed control

The switching element (a power MOSFET) switches back and forth at a frequency of several tens of kHz. This controls the ON/OFF duty rate per cycle and thus changes the voltage applied to the fan motor to control the rotation speed.

Refrigerant Circuit

Units are equipped with independent refrigerant circuits. Each circuit is equipped in the liquid line with:

- Strainer
- Drier
- Electronic expansion valve
- Stop valve
- Sight glass

Gas line:

- Check valve
- Stop valve (option)
- Safety valve
- 4 way valve (Heat Pump versions)

Compressor protection:

- High pressure switch
- Low pressure control
- Safety valve (option)
- Protection control

Others:

- Accumulator (Heat Pump versions)
- Receiver (Heat Pump versions)

Electrical Power and Control Panel

ON/OFF switch, power supply, operation and alarm LED's. Electrical power and control panel complete with contactors and circuit protectors for the compressors and fans. The power section conforms CEN-60204 standard. The electrical panel, inside the supporting structure, is fitted with a sealed door and is suitable for outside installation (Air cooled models).

The setting functions are located on the rear side of the panel and are accessible by opening the control panel doors.

Microprocessor Control System

HITACHI has designed a control system based on HITACHI technology. A sliding valve (which adjusts the point of compression) located in the compressor, controls the compressor's capacity to adapt to the required load. This controls the leaving water temperature within a range of +/- 0.5 °C. The microprocessor monitors various points in the chiller, controlling each refrigeration circuit through its characteristic variables.

The microprocessor has up to 24 protection codes, 15 of which are different for each cycle. This guarantees safety during unit operation. The alarms are monitored through an interface and can be read in four 7-segment displays. The control system includes all the operating times required to protect the screw compressors and the electrical system.

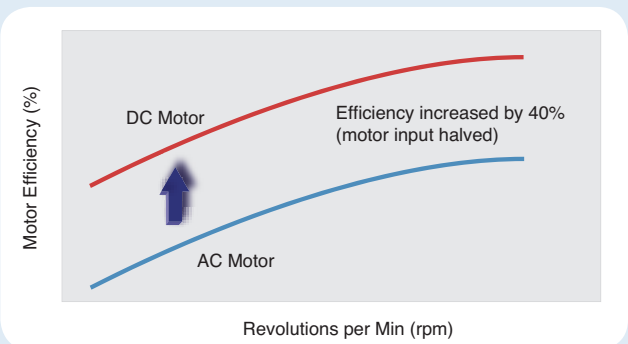

Chillers Central Station (CSC-5S)

CSC-5S newly developed for Hitachi screw chillers, provides individual control, quantity control and monitoring. It can be used for up to 8 chillers and installed according to the customer's airconditioning environment. By remote control, the functions can be checked from the control room, so there's no need to go out to the machine room for checking, unlike conventional machines.



A close-up photograph of a woman with dark hair and eyes, wearing a white top, looking directly at the camera with a slight smile. The background is a solid light blue color. A white rounded rectangular box is overlaid on the lower left side of the image, containing the text "Options & accessories".

Options & accessories

	Specifications	St.	A/C C/O	A/C H/P	W/C	C/L	Remarks
General	Low Noise Option / Super Low Noise All Painted Chiller Lower Guardnet Rear Cover Wooden Crate		• • • • •	• • • • •	• • • • •	• • • • •	
Low Water Temperature	Outlet Temperature: 4~0°C (Low 1) Outlet Temperature: -1~-5°C (Low 2) Outlet Temperature: -6~-10°C (Low 3)		• • •		• • •	• • •	
Compressor	Extended Minimum Capacity Control (only standard for WG2, not available for AG2) Compressor Safety Valve Discharge Valve Suction Valve Twin Compressor Safety Valve	•	• • • •	• • • •	• • • •	• • • •	DSW7-3 ON
Control System	Compressor Circuit Breaker Protector Fan Motor Circuit Breaker Protector Change Over Local/Remote Control Individual Alarms Compressor Operation Hour Meter Pump Freeze Protection Operation Pump Operation Circuit Non- Voltage Contact for Remote Indicators DC24V Remote Control Short Period Power off Protection Heating Operation In High Ambient Magnetic Circuit Breaker	• • • • • • • • • •	• • • • • • • • • • •	• • • • • • • • • • •	• • • • • • • • • • •	• • • • • • • • • • •	For Each Compressor For Each Fan Motor by Alarm Code Pump ON/OFF Operation Pump Operation Contact Pump, Chiller, Alarm Level or Pulse
Condenser	Coated Fin Copper Fin Corrosion High Condensing Water Heat Recovery (A/C)	•	• • •		• • •	• • •	

NA: Not Available A/C: Air Cooled W/C: Water Cooled C/O: Cooling Only H/P: Heat Pump ST: Standard C/L: Condenserless

Options & accessories continued

	Specifications	St.	A/C C/O	A/C H/P	W/C	C/L	Remarks
Refrigerant cycle	Independent Circuit	•					Standard: Press Display on Panel
	Suction Valve		•	•	•	•	
	Dual Safety Valve		•	•	•	•	
	Pressure Display (High and Low)	•					
	Suction Pressure Relief Valve				•	•	
	STEK Coupling		•	•	•	•	
	Pressure Port		•	•	•	•	
Evaporator	PED Certificate (97/23/EC)	•					PED: Pressure Equipment Directive With Companion Flanges
	PN16 Flanges		•	•	•	•	
	Water Differential Pressure Switch		•	•	•	•	
	Water Flow Switch		•	•	•	•	
	Water Cooler Trace Heater		•	•	•	•	
	Common Water Pipe		•	•	•	•	
	Brine Applications:		•	•	•	•	
	– Category 1 (0°C - 4°C)						
	– Category 2 (-1°C - -5°C)						
	– Category 3 (-6°C - -10°C)						
Drain water valve		•	•	•	•		
Water Strainer		•	•	•	•		
Others	Witness Test		•	•	•	•	
	Anti-vibration Rubber Mats		•	•	•	•	
	Double Packing		•	•	•	•	

Low Noise Option

Available for all models in the SAMURAI range. Reduces sound level by 4 dBA. When this option is requested, 8-pole fans specially designed for maximum noise reduction replace the standard 6-pole fans. The area that houses the compressor is also covered with acoustic insulating material and in addition, a lead-based sandwich-type coating is directly applied to the compressor housing.

Low Water Temperature

Some applications require water outlet temperatures below 5 °C (minimum cold water outlet temperature reachable with standard models). In this case it will be necessary to request that option. Depending on the required outlet temperature there are 3 categories:

- Category 1:
Outlet temperature 0 to 4 °C
- Category 2:
Outlet temperature -1 to -5 °C
- Category 3:
Outlet temperature -6 to -10 °C

Compressor & Fan Circuit Breaker

When requesting that option, the overintensity fuses are replaced with magnetic switches (circuit breakers) in the compressor's power circuit. The magnetic switches permit the power circuit to be reset immediately. Thus there is no need to replace any components as you would if the system were protected with fuses. The automatic switches have a trip current that is more precise than fuses, as the automatic switches are adjusted directly by HITACHI.

Central Station (CSC-5S)

CSC-5S newly developed for the HITACHI screw chillers, provides individual control, quantity control and monitoring. It can be used for up to 8 chillers and installed according to the customer's air-conditioning environment. By remote control, the functions can be checked from the control room, so there's no need to go out to the machine room for checking, unlike conventional machines.

BMS control (HARC-70 CE1)

To integrate the chiller in the global building system, you must request this interface. This interface allows the connection of up to 4 chillers to a global management system using the LONWORKS communications protocol. The system is easy to install, since with two wires it is possible to achieve communication between the chillers and the systems control unit through the HARC-70CE1. From there it will be possible to manage the unit's ON/OFF and select the desired value of the cold water outlet temperature.

It is also possible to obtain information about:

- Unit status (ON/OFF/Operation status)
- Setting outlet water temperature
- Water inlet/outlet temperature
- Protection codes

Numbered Cables

The unit is delivered with documentation that details the electrical diagrams with the location and numbering of each wire.

Rear Guard Net

It is possible, if necessary, to request a protective net for the rear of the chiller, similar to the side protection net.

Copper Fin

For some special applications, i.e. saline environments, it might be necessary to replace the Aluminum in the condensers with Copper to protect against the corrosive environment. In addition, the main parts of the condenser are coated with anti-corrosion paint.

All Painted Chiller

It is possible to order a chiller that is specially protected against corrosion. In this case, the unit's components have a special anti-corrosion treatment. The main parts are painted with anti-corrosion paint. In case of salty or highly corrosive environments, request this option together with the Cu/Cu condensers.

High Condensing Water

When it is needed, one application with, for instance, Dry coolers, High Condensing Temperature is needed to reduce as much as possible the size of the condensing unit. In this case it is possible to order this option and to reach 55°C as Water condenser outlet temperature.

Suction and Discharge Valves for Compressor

To be able to close the refrigerant circuit and thus make it easier to maintain the compressor, ball valves can be installed in the compressor suction and/or discharge lines. Whenever a ball valve is placed at the discharge, a safety valve will automatically be installed in the compressor.

Dual Safety Valve

Consists of installing two safety valves in parallel, of which only one is operational. This way it is possible to prevent having to reload the refrigerant cycle each time you must change the valve, be it for maintenance or operating reasons.

Compressor Safety Valve (Dual safety Valve)

It is also possible to install the safety valves at the compressor outlet if the customer considers this appropriate. The double valve serves the same purpose as in the previous option.

Suction Pressure Relief Valve

An additional pressure relief in the suction side of the compressor could be installed if required by the customer.

Insulation Suction Pipe

It is possible to add insulations in the suction side upon request.

STEK Coupling

These can be installed in place of flare connections and consist of an adapter that has a welded copper tube, a nut, and a copper joint to guarantee at all times a copper-copper contact in the joint.

PN 16 Flanges

To connect the unit to the cold water line, PN 16 flanges can be welded to the unit, plus the corresponding watertight seals that

enable and ensure a perfect installation and absolute water tightness.

Water Differential Pressure Switch

The standard units have a protection system to prevent them from being connected when the water pump is stopped. It is also possible to detect any obstructions that may exist in the water pipes by installing a switch that evaluates the pressure difference between the water inlet and outlet pipes.

Water Flow Switch (installed on site)

This option achieves the same effect as the differential pressure switch, but uses another kind of mechanism. In this case a switch is installed that evaluates the flow circulating through the installation. This switch is provided separately, and must be installed on site.

Water Cooler Trace Heater

In cold climates, it may be necessary to install this accessory to protect the evaporator from freezing. It is an electric heater that is activated when the ambient temperature falls below 2°C, and protects the evaporator (Joule effect) from internal frost.

Common Water Pipe

Using this option it is possible to have only one inlet and one outlet connection for the multiple plate heat exchanger units.

Witness Test

If the customer so requires, it is possible to witness the test of their unit at the factory. During this inspection, the customer can verify the appearance, the dimensions, the cooling capacity, the activation of the various safety devices, temperature control, the possible existence of refrigerant leaks, etc.

Foundation Rubber Anti-Vibration Mounts

This option is available to reduce, to the maximum extent possible, the transmission of vibrations to the structure on which the unit is placed. It consists of placing a series of rubber anti-vibration pads underneath the unit at the time of installation. For additional details on how to do this, see the Technical Catalogue.

A man with a short beard and a grey t-shirt is wearing a headset. He is looking down at a white laptop that he is holding with both hands. The background is a light-colored wall with horizontal blinds.

Hitachi Air Conditionings Products Europe SA (HAPE), the industrial division for air conditioning products in Europe is committed to manufacture products of the highest quality with full respect for the environment. Proof of this are the company's ISO 9002 and ISO 14001 certifications.

Quality process & maintenance

During the manufacturing process of the Samurai chillers both work in progress and finished products are submitted to various controls that ensure compliance with the established specifications.

The different checks that are made can be divided into two categories:

- Electrical or operating tests
- Pressure and leakage tests

These tests are made both on the assembled components at different stages during the production process and on the finished product. For the electrical and operating tests, once the electronic panel is assembled and all the pertinent connections have been made, an exhaustive test is performed of all the electric/electronic components, by using a simulator.

Mechanical tests are performed at various stages, checking especially the status of the many welds that are made. Thus, every time a set of copper pipes is made or condensers are assembled, and before they are mounted in the unit, they are filled with refrigerant at maximum design pressure to check that there are no leaks. To do this, special equipment is used that detects concentrations of refrigerant of as little as 0.8gr/year. Once these components are 100% inspected, they are assembled.

After the assembly of the entire unit has been completed, a new leak test is performed, especially inspecting all the mechanical joints. As many as 16 critical points in the refrigerant cycle are exhaustively controlled, in addition to checking each and every single weld in the system.



A computer system controls the results of the Commercial Test, obtaining in real time all the system variables and checking the correct operation of the unit.

During this test, the chiller is placed in operation at standard power.

Meanwhile, various operating tests are made, checking:

- the correct operation of the fans: how many are working and the correct rotation direction
- the unit's control capacity depending on the cold water outlet temperature
- ON/OFF by remote control
- activation of the various safety devices that control the correct operation of the refrigerant cycle, simulating extreme operating conditions
- the operation of the chiller's ON/OFF control by the circuit pump.

During the COMMERCIAL TEST, all the critical points and welds in the chiller are checked again to detect any possible refrigerant leaks. As a result of the COMMERCIAL TEST, real time data for all the refrigerant cycles, load water status and ambient temperature variables are obtained by means of a series of strategically placed probes (temperature, pressure, flow, intensity and current).

All this data is processed by a control computer that continuously reports on the unit's performance. Once all the nominal values are reached, a check is made to ensure that all the measured parameters meet the declared levels (cooling capacity, power input, etc). The unit is then declared ready for delivery to the customer.



All the chillers are submitted to a Commercial Test, during which the unit is tested by simulating actual operating conditions.

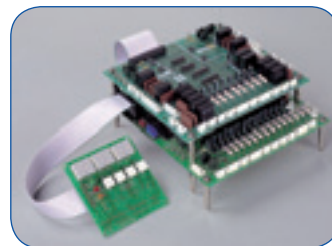

SAMURAI electronic control system simulator used in training courses.

Operating Space

Thanks to the location and choice of components, especially the plate heat exchanger, the SAMURAI chiller has lots of space inside, and permits problem-free access to all components to perform all necessary checks.

Compressor

It is possible to specify optional extras to facilitate ease of servicing, for example, the suction and discharge valves (that block off the compressor), double circuit and compressor safety valves, that permit replacing one of them without having to empty the refrigeration circuit, etc.

Easy Handling

When the time comes to turn on the unit, you will see how simple HITACHI's electronic control system really is. Starting with the control panel, which has been fully simplified so that it is totally comprehensible. The control panel consists of:

- 2 double 7-segment LED's
- 4 selection buttons.

From this simple control panel you have access to all the unit's variables. With the ON and OFF buttons you can turn the unit on and off. With the "CHECK" buttons, you can access the log of the last 10 fault codes, the indication of the capacity control value, and the indication of the various different variables of the refrigerant circuit. These variables are, for example, for each cycle: discharge and suction pressures, discharge and suction temperatures, temperatures of the condenser liquid, cold water inlet and outlet temperature, etc.

Up to 24 different alarms may show up as error codes, each of which indicates a different fault in the unit's operation. Furthermore, if the fault occurs in a single refrigerant circuit, the display will show in which one, in order to make maintenance work easier.

Easy to Program

HITACHI has searched for the maximum flexibility when configuring SAMURAI chillers. This makes it easy to adapt them to any kind of installation, either for Air Conditioning applications or for industrial cold water supply applications.

All the unit's operating variables are totally configurable. All you need to do is to manipulate some micro-switches located in the general electronic section, behind the control panel. By simply selecting the status of these micro-switches (ON/OFF), you can select the desired temperature, control band, cooling speed, etc. This simple programming method provides a reliability that is unique in the market, since it avoids complicated programming routines that if not correctly performed, can cause serious operating problems. HITACHI has managed to develop a very simple programming system that is very precise and extremely reliable. It is therefore ideal both for Air Conditioning systems and for demanding industrial processes.

Services

HITACHI has a large network of distributors throughout Europe, who are always available to provide any required technical information about their products. By providing training courses and technical documentation. HITACHI wishes to provide its customers with the maximum possible amount of knowledge regarding its SAMURAI chillers.

Specifications in this catalogue are subject to change without notice in order that HITACHI may bring the latest innovations to their customers, omitting typing errors.

Hitachi Europe Ltd
Whitebrook Park
Lower Cookham Road
Maidenhead
Berkshire
SL6 8YA
United Kingdom

email: aircon.enquiries@hitachi-eu.com

www: www.hitachiaircon.com

HELGB-CHL-001

Distributed by:

